

Nominal Diameter		Main Dimension class 600									
inch	mm	d	D	D1	D2	b	n- $\phi$ d	L	H <sub>open</sub>	W	
2"	50	51	165	127.0	92	26	8- $\phi$ 19	292	448	250	
2 1/2"	65	64	190	149.2	105	29	8- $\phi$ 22	330	508	250	
3"	80	76	210	168.3	127	32	8- $\phi$ 22	356	553	300	
4"	100	102	273	215.9	157	38	8- $\phi$ 26	432	655	350	
5"	125	127	330	266.7	186	45	8- $\phi$ 29	508	723	400	
6"	150	152	356	292.1	216	48	12- $\phi$ 29	559	886	450	

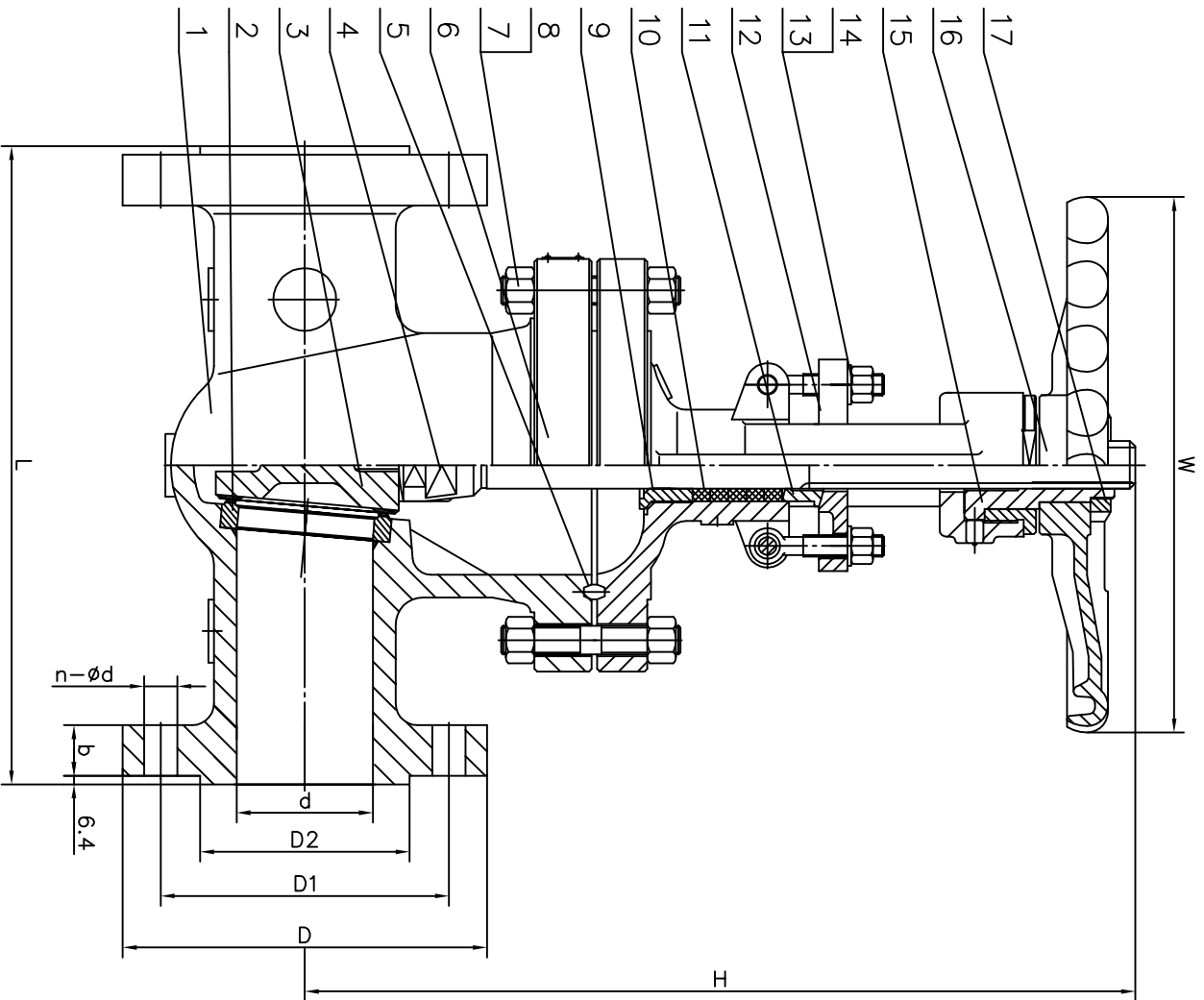

17	H.W.Lock Nut	ANSI 1020	
16	Hand Wheel	Duction Iron	
15	Stem Nut	ZCuAl10Fe3	
14	Gland Nut	ASTM A194 2H	
13	Gland Eyebolt	ASTM A193 B7	
12	Gland Flange	ASTM A216 WCB	
11	Gland	ASTM A182 F6a	
10	Stem Packing	Graphite	
9	Backseat bushing	ASTM A182 F6a	
8	Bonnet Nut	ASTM A194 2H	
7	Bonnet bolt	ASTM A193 B7	
6	Bonnet	ASTM A216 WCB	
5	Ring Joint	Soft Steel	
4	Stem	ASTM A182 F6a	
3	Wedge	A216 WCB+13Cr	
2	Seat Ring	ASTM A105+13Cr	
1	Body	ASTM A216 WCB	
NO	PART NAME	MATERIAL	REMARKS

GATE VALVE CLASS 600

Design and Manufacture	API 600
Face to Face Dimensions	ANSI B16.10
Flange Ends Dimensions	ANSI B16.5
Pressure Test	API STD.598
JRW VALVE DIVISION	DATE 10.08.2003